

Data visualization for large zebrafish screen

Antonio de la Vega de León
CNB Young Researchers Abroad 2018

Introduction



Zebrafish (*Danio rerio*)

<https://you.stonybrook.edu>



Tanya Whitfield
Dpt. of Biomedical Science

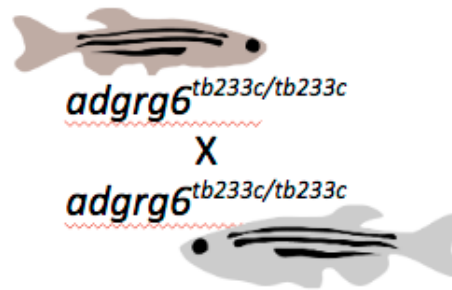

Adgrg6

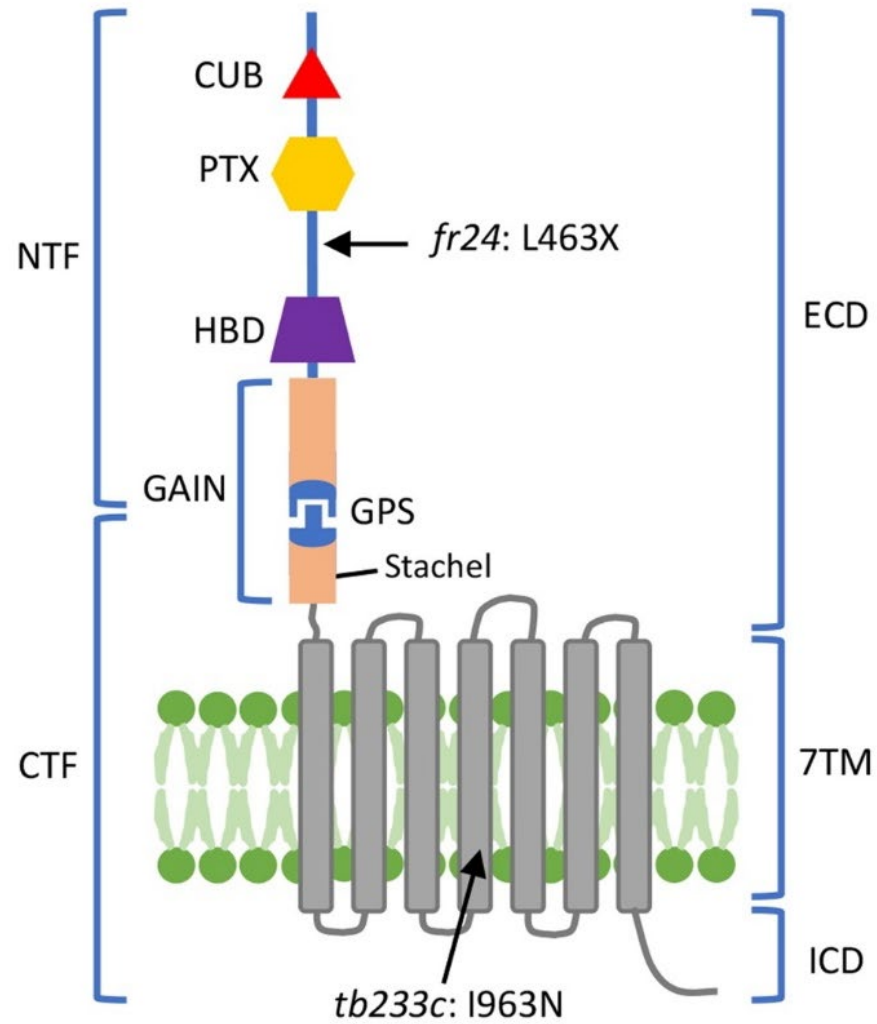

Effects of *adgrg6* mutation

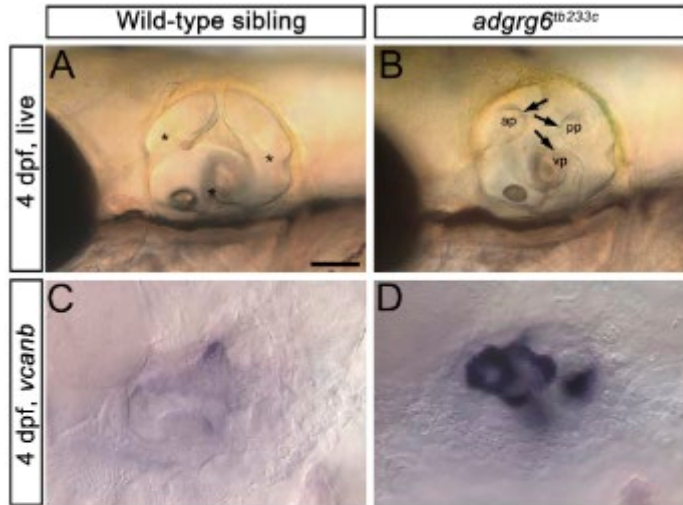

Over expression
of *vcanb*

vcanb assay

3120 compounds tested

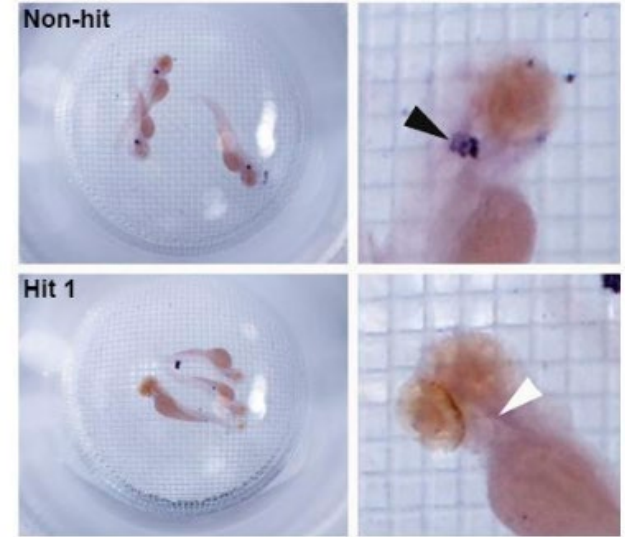
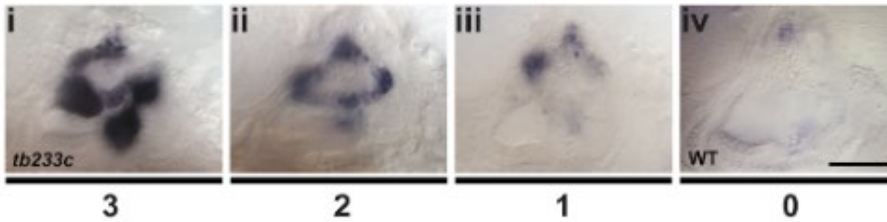

| Category | Vcanb score sum |
|----------|-----------------|
| A | 0-2 |
| B | 3-4 |
| C | 5-6 |
| D | 7 |
| E | 8-9 |
| F | Abnormal |
| G | No fish |

Chemoinformatics visualization

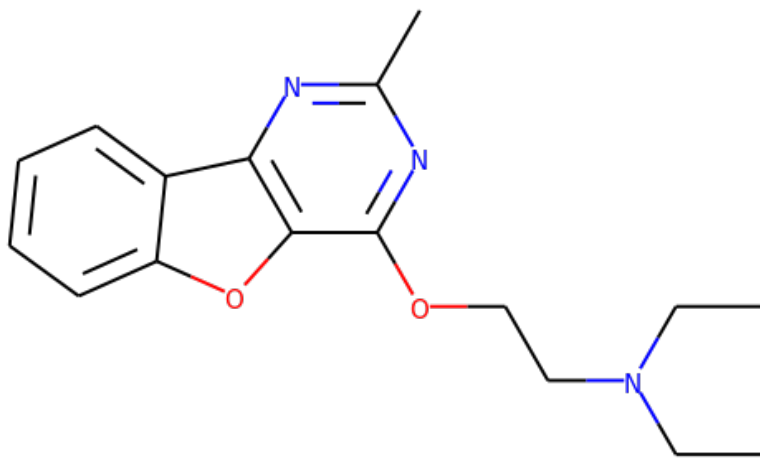

Properties:
Activity
Solubility
Absortion

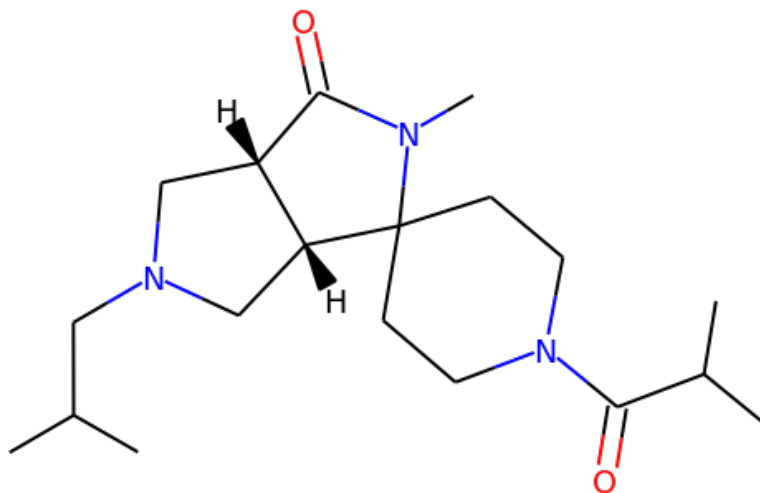

Polar scatterplot

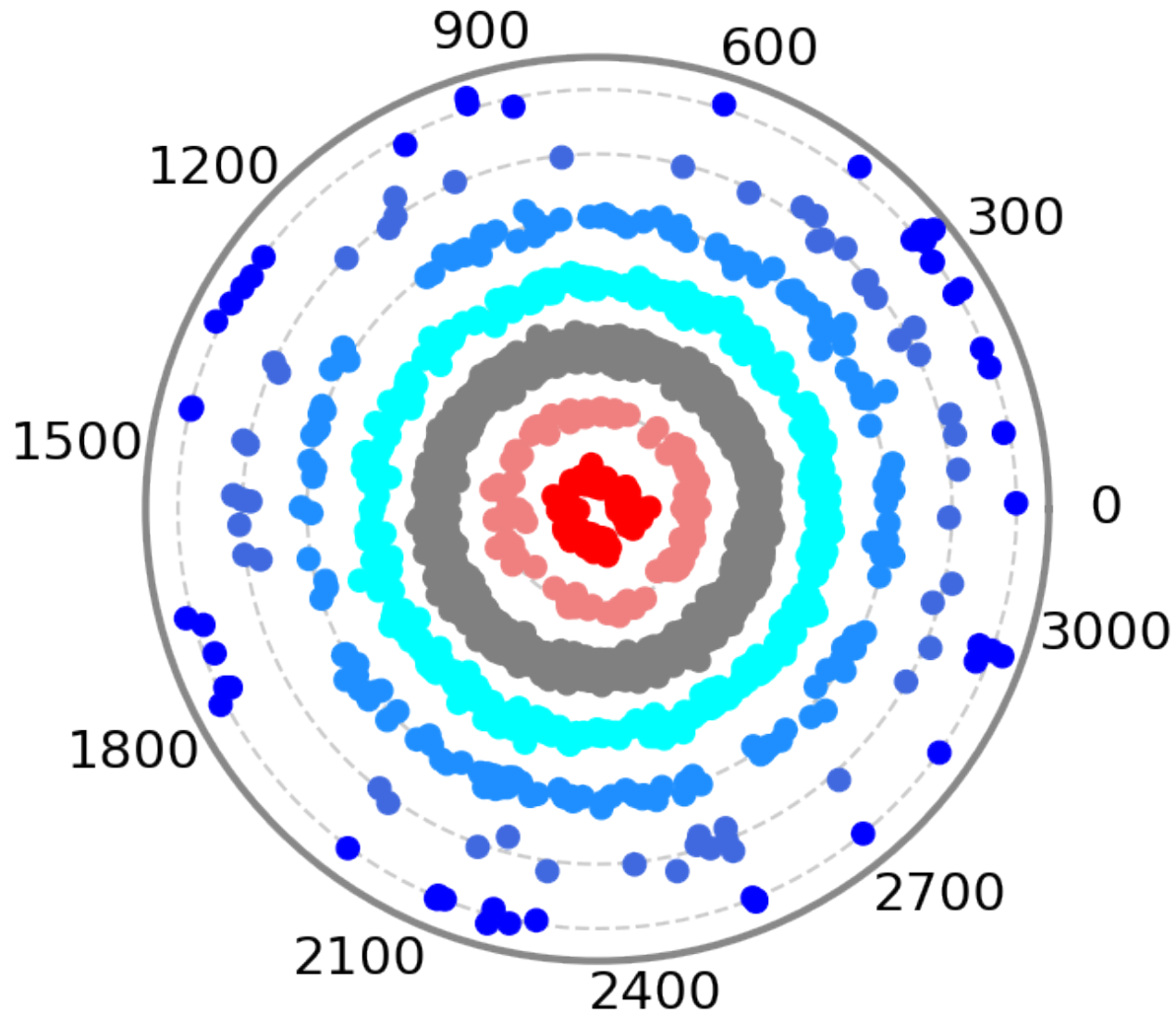

mbp assay

91 compounds tested on mbp assay

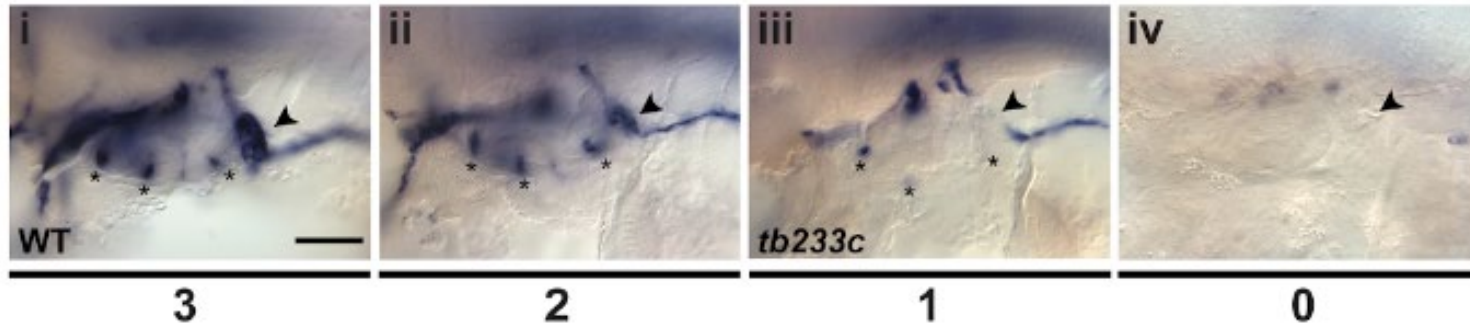

| Category | <i>mbp</i> score sum |
|-----------------|----------------------|
| Rescue | >3.5 - 9 |
| No rescue | >1.5 - 3.5 |
| <i>mbp</i> down | 0 - 1.5 |



Final polar scatterplot

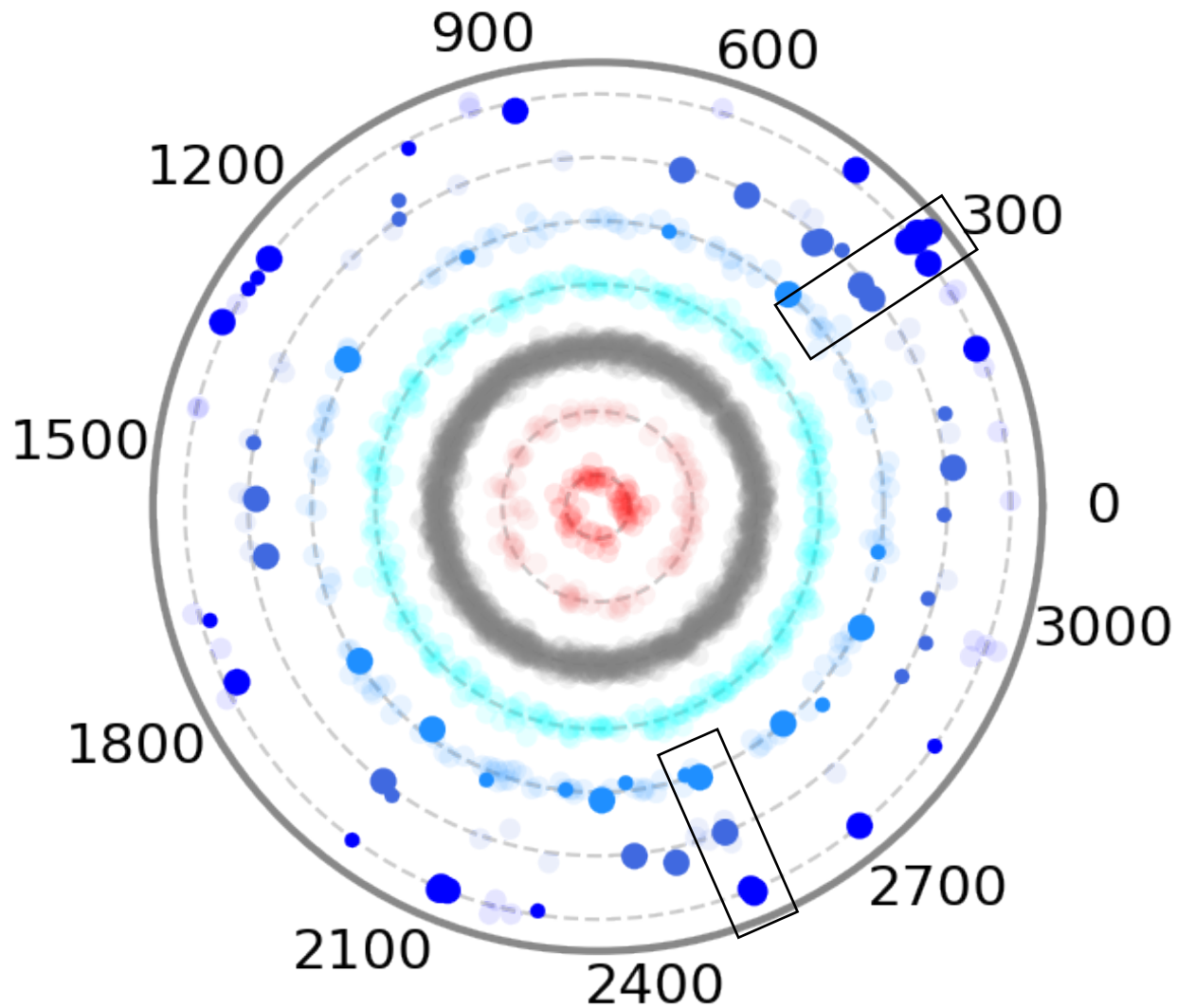

Compound network

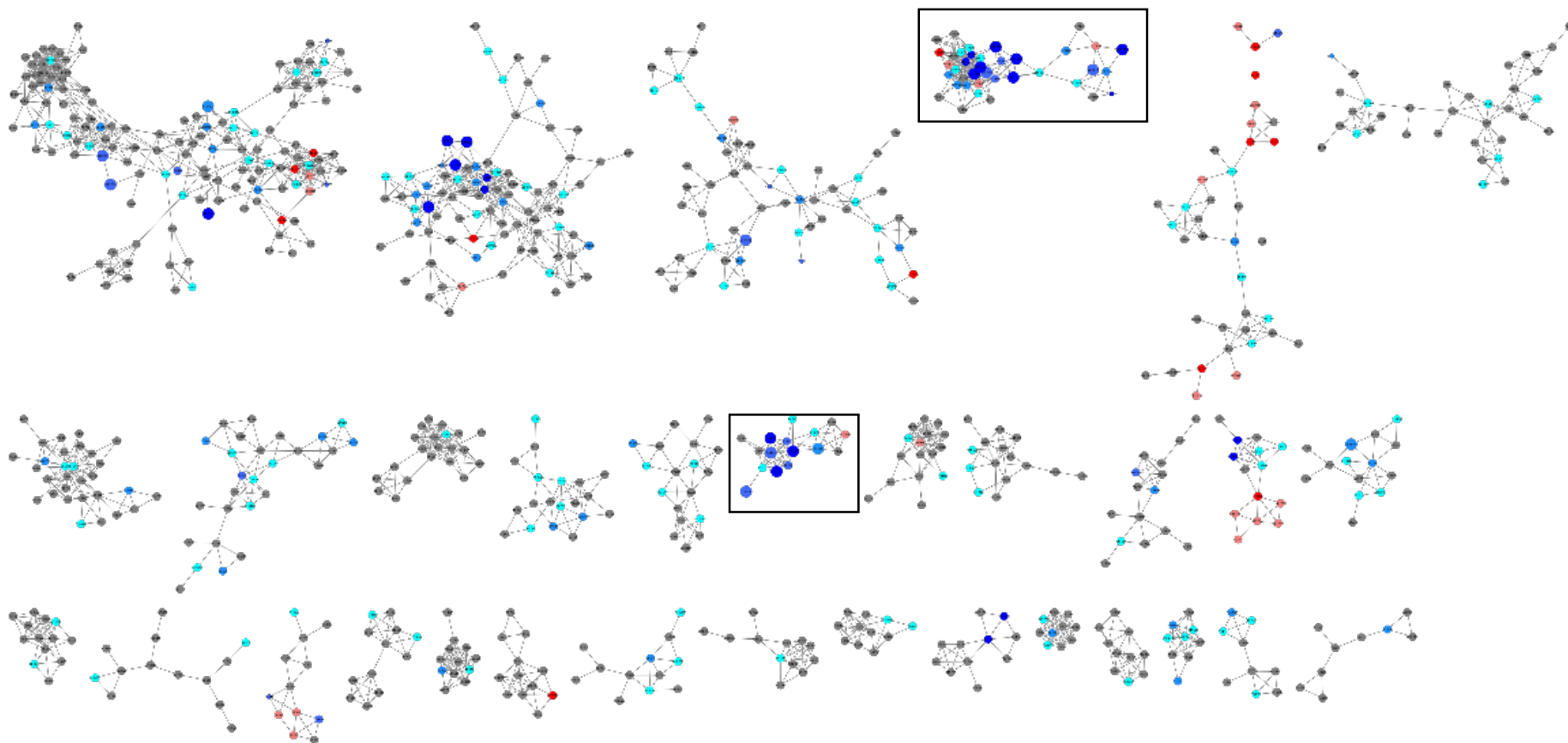

Dihydropyridine cluster

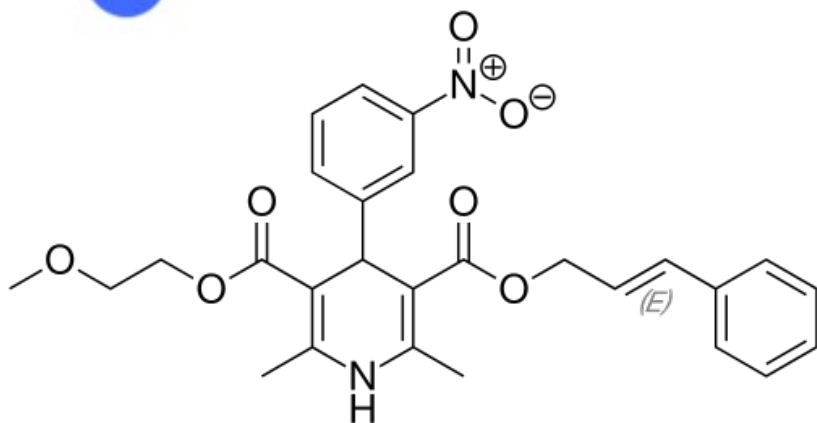
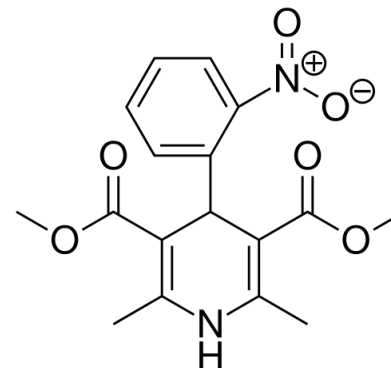
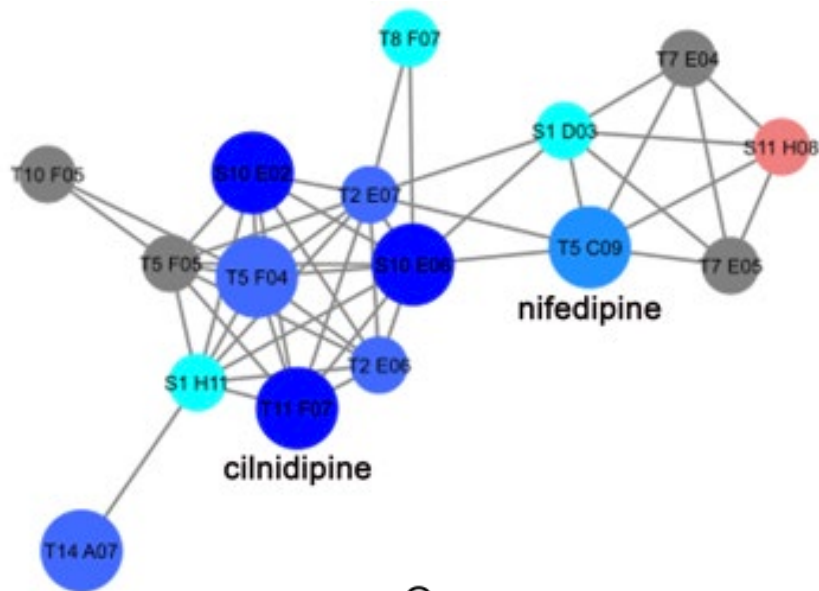

Interactive visualizations

Polar scatterplot

https://adlvd1.github.io/visualizations/polar_scatterplot_whitfield_vcanb.html

Compound network

https://adlvd1.github.io/visualizations/network_whitfield_vcanb_mbp/index.html

Conclusion

Consistency in presentation (colour, sizes, shapes) helps emphasize important information

In most cases, it is better to create different visualizations to focus on different aspects of the analysis